

RIGHT SIDE VIEW

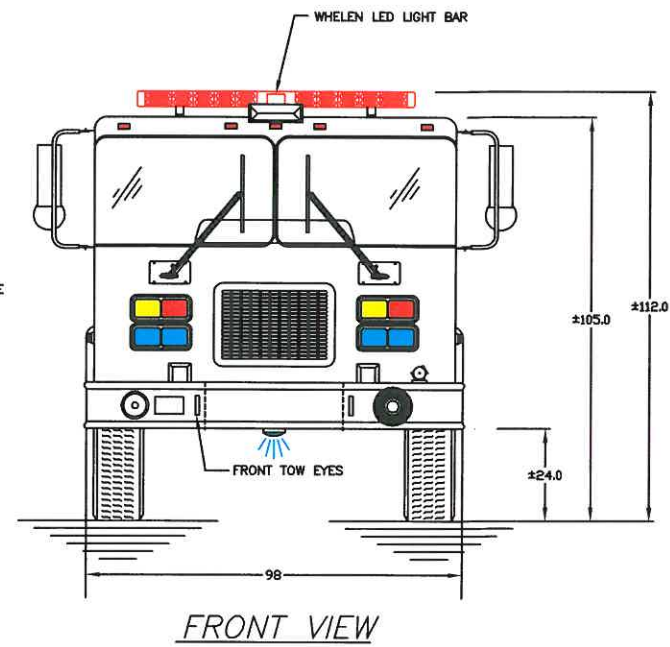

FRONT VIEW

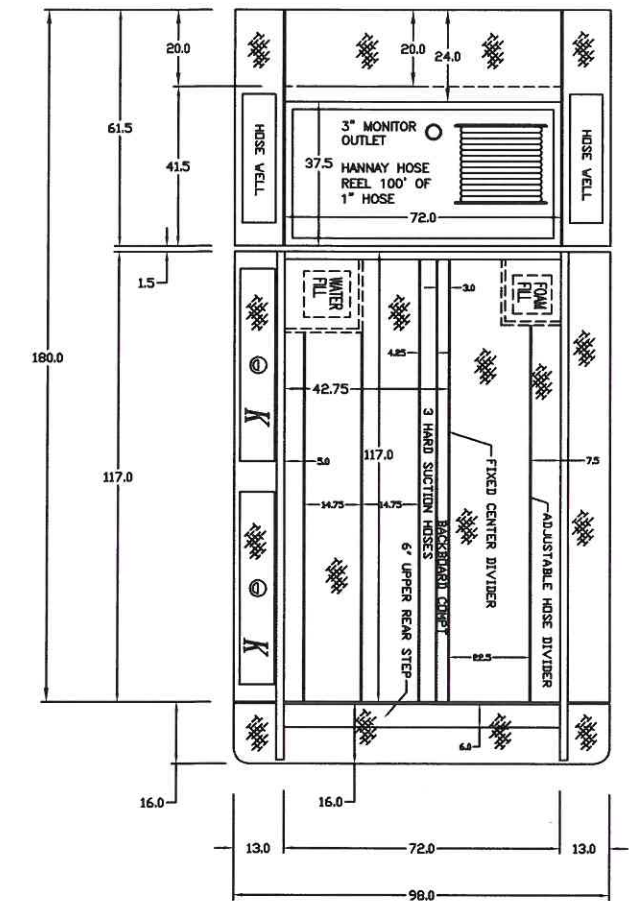

TOP VIEW

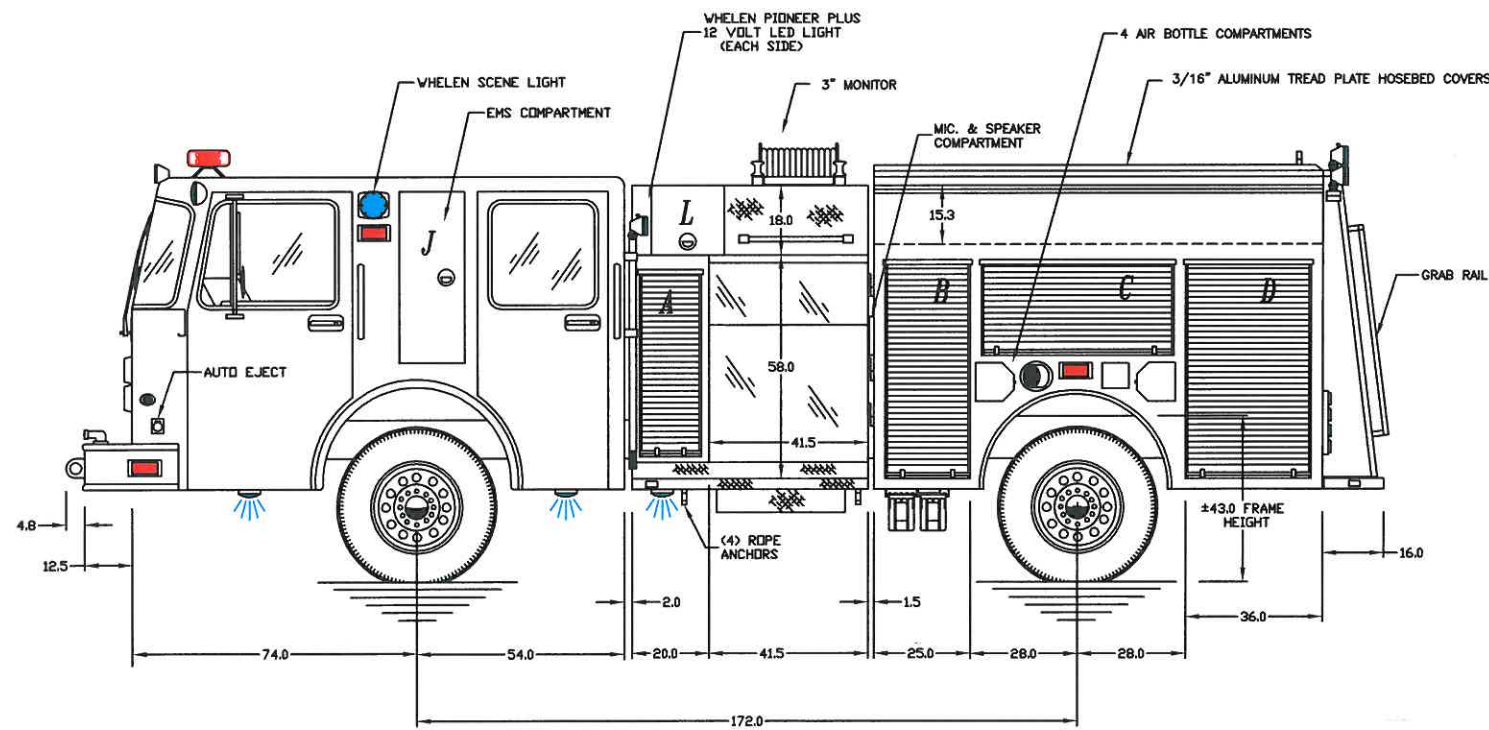

LEFT SIDE VIEW

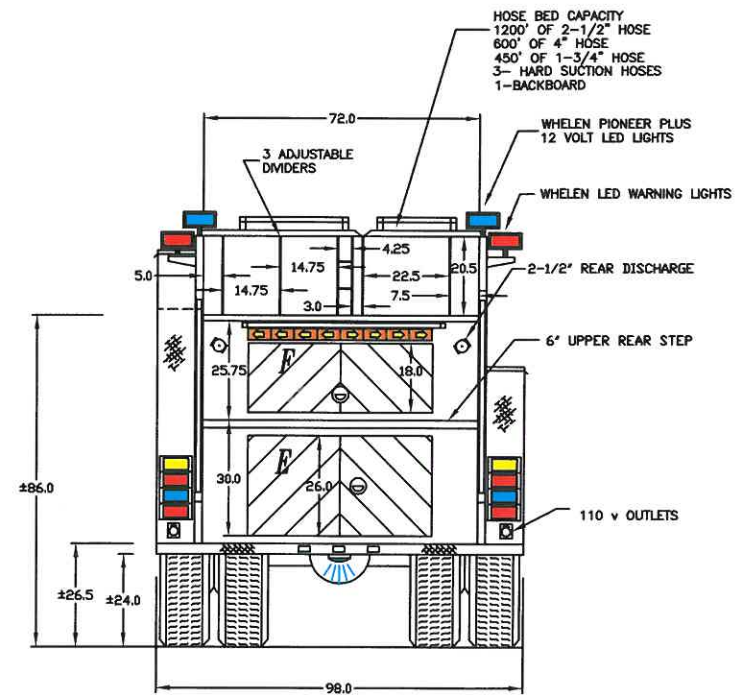

REAR VIEW

COMPARTMENT DIMENSIONS

INSIDE	OPENING
A. 52.75" Hx20" Wx72" D	A. 44" Hx13" W
B. 60" Hx25" Wx24/13" D	B. 52H"x19.5" W
C. 28" Hx56" Wx13" D	C. 20.5" Hx47" W
D. 60" Hx36" Wx24/13" D	D. 52.5" Hx30" W
E. 30" Hx50" Wx22" D	E. 26" Hx50" W
F. 25.75" Hx72" Wx22" D	F. 18" Hx50" W
G. 46" Hx25" Wx24/13" D	G. 38" Hx19.5" W
H. 14" Hx56" Wx13" D	H. 10" Hx48" W
I. 46" Hx36" Wx24/13" D	I. 38" Hx30" W
J. 43" Hx17" Wx23" D	J. 43" Hx17" W
K. 15.25" Hx117" Wx13" D	K. 9" Hx50" W
L. 18" Hx24" Wx72" D	L. 14" Hx18" W

HI-TECH EMERGENCY VEHICLE SERVICE  
444 W. GREGER ST. OAKDALE, CA. 95361 (209)847-3042

SANTA BARBARA CITY F.D.

SCALE: DATE: 7-6-12 APPROVED BY: DRAWN BY: B RUTHMAN REVISED: 7-25-12

750 GAL. POLY TANK

CAD PRODUCED DRAWING DRAWING NUMBER 1-E