

RIGHT SIDE VIEW

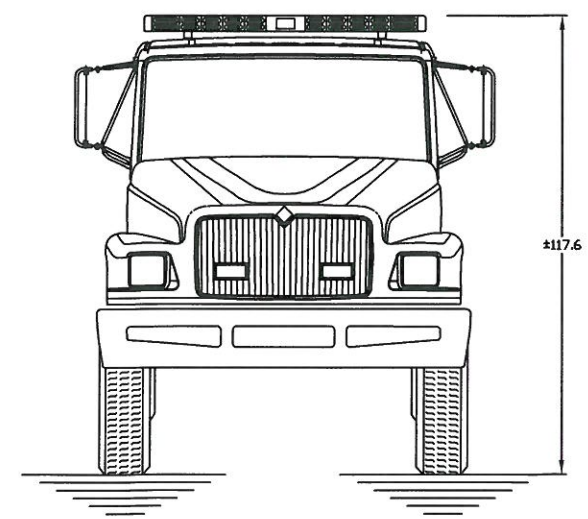

FRONT VIEW

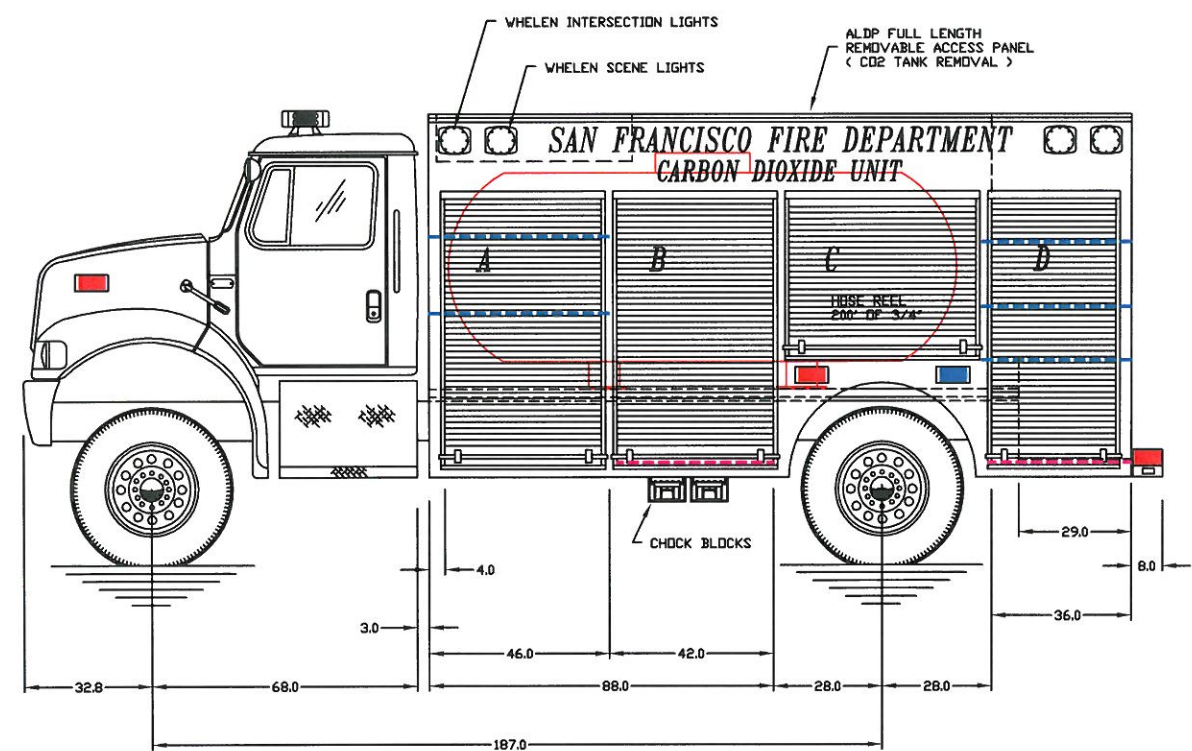

LEFT SIDE VIEW

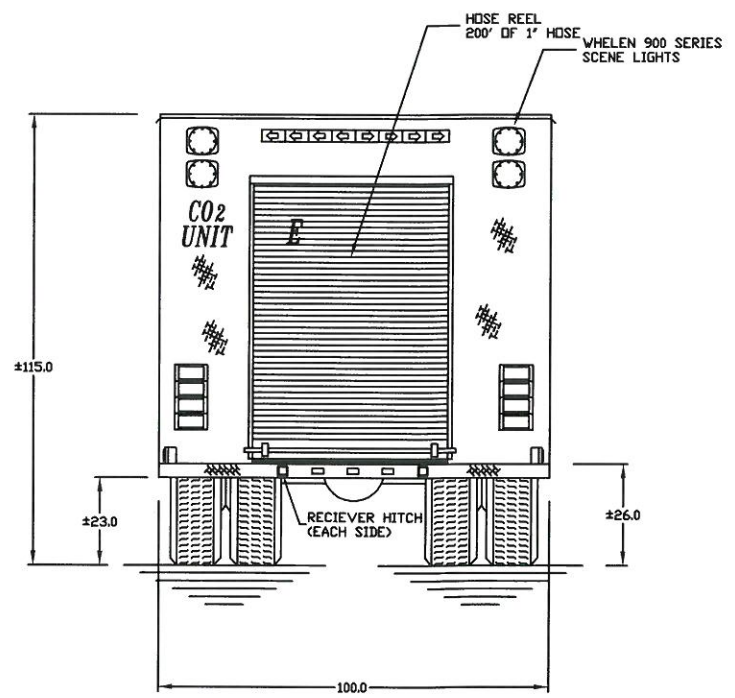

REAR VIEW

NOTE: DOOR FRAME OPENING HEIGHT IS REDUCED BY 4.5"
OVERALL FRAME OPENING WIDTH IS REDUCED BY 2.75"

ADJUSTABLE SHELF LOCATION - - - - -

SLIDE OUT TRAY LOCATION - - - - -

COMPARTMENT DIMENSIONS	
APPROXIMATE INSIDE	DOOR FRAME OPENING
A. 46"Wx77.5"Hx24"D	A. 40"Wx70"H
B. 42"Wx89.5"Hx24"D	B. 40"Wx70"H
C. 56"Wx61.5"Hx24"D	C. 48"Wx42"H
D. 36"Wx89.5"Hx24"D	D. 32"Wx70"H
E. 52"Wx88"Hx29/36"D	E. 52"Wx70.0"H

HI-TECH EMERGENCY VEHICLE SERVICE
444 W. GREGER ST. OAKDALE, CA. 95361 (209)847-3042

SAN FRANCISCO F.D.

SCALE: DATE: 3-2-09 APPROVED BY: DRAWN BY: B. RUTHMAN REVISED: 4-3-09

INTERNATIONAL 4900 CHASSIS

CAD PRODUCED DRAWING DRAWING NUMBER 1-D