

RIGHT SIDE VIEW

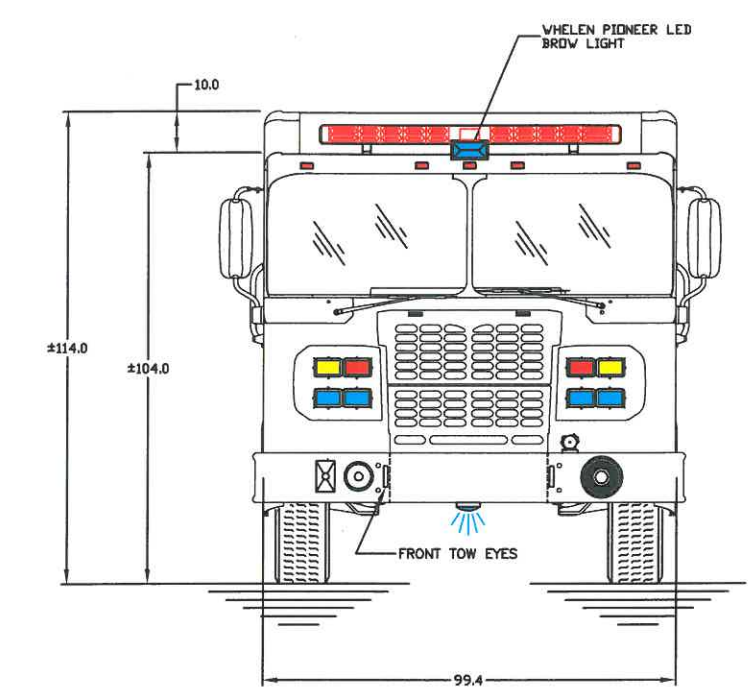

FRONT VIEW

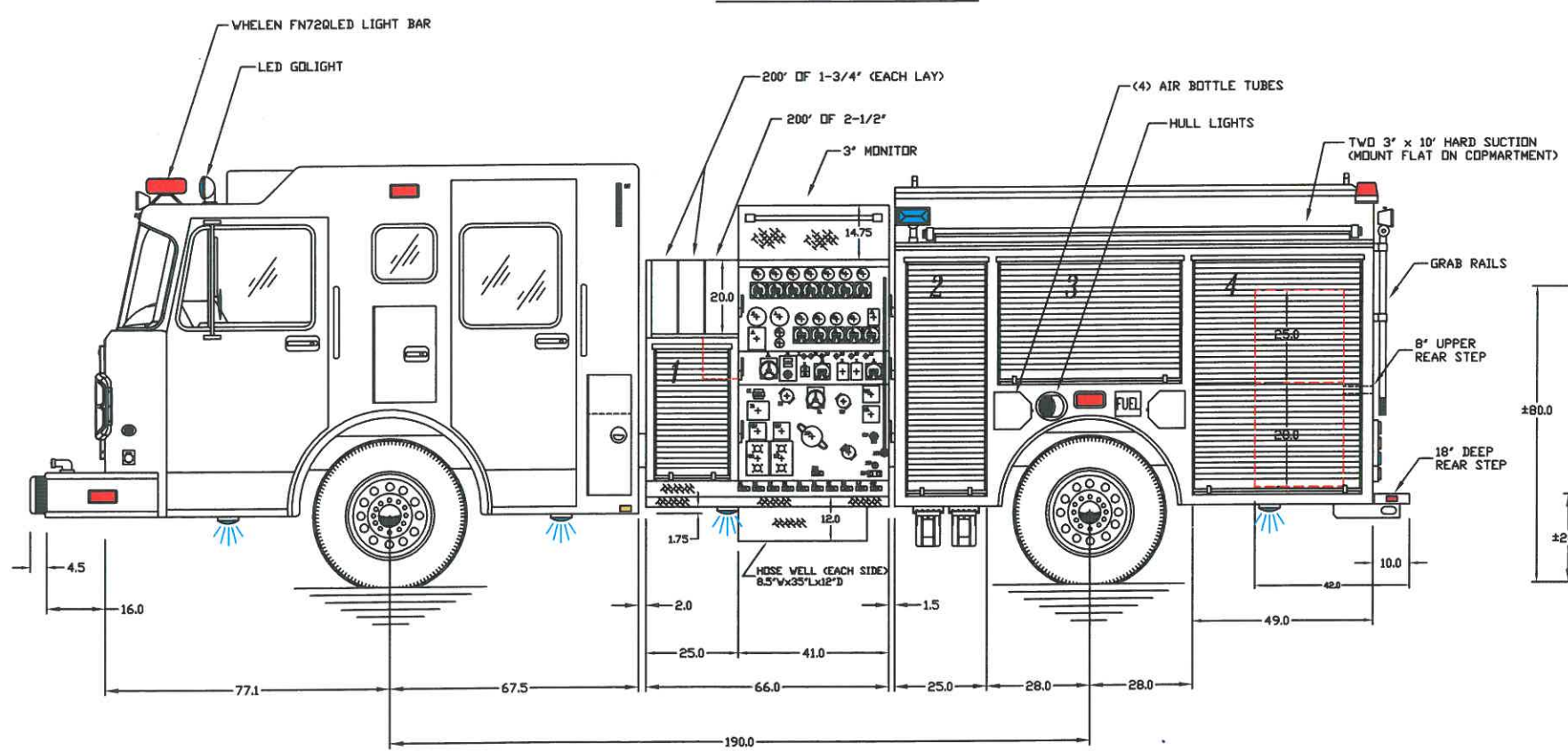

LEFT SIDE VIEW

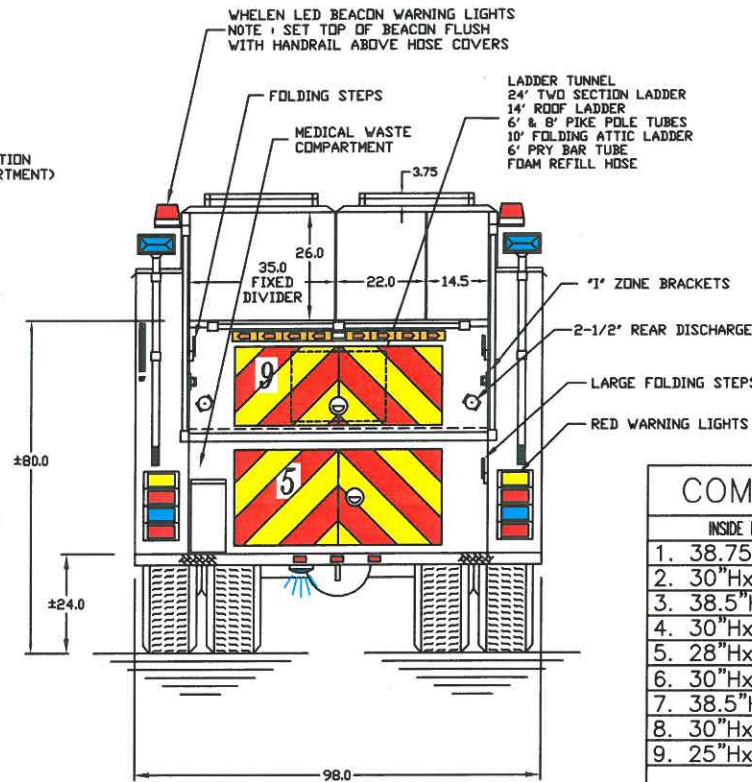

REAR VIEW

COMPARTMENT DIMENSIONS		
INSIDE DIMENSIONS	UPPER HALF DIMENSIONS	APPROXIMATE DOOR OPENING
1. 38.75"Hx25"Wx98"D	1. 38.5"Hx25"Wx13"D	1. 30.25"Hx17"W
2. 30"Hx25"Wx24"D	2. 38.5"Hx25"Wx13"D	2. 60"Hx19"W
3. 38.5"Hx56"Wx13"D	3. 31"Hx48"W	3. 31"Hx48"W
4. 30"Hx49"Wx24"D	4. 38.5"Hx49"Wx13"D	4. 60"Hx43"W
5. 28"Hx50"Wx24"D	5. 23"Hx50"W	5. 23"Hx50"W
6. 30"Hx25"Wx24"D	6. 38.5"Hx25"Wx13"D	6. 60"Hx19"W
7. 38.5"Hx56"Wx13"D	7. 31"Hx48"W	7. 31"Hx48"W
8. 30"Hx49"Wx24"D	8. 38.5"Hx49"Wx13"D	8. 60"Hx43"W
9. 25"Hx72"Wx24"D	9. 19"Hx50"W	9. 19"Hx50"W

HOSE BED DIMENSIONS 72"Wx26"Hx98"L
 700' OF 5" HOSE 1200' OF 3" HOSE
 HI-TECH EMERGENCY VEHICLE SERVICE
 444 W. GREGER ST. OAKDALE, CA. 95361 (209)847-3042

SAN JOSE F.D.

SCALE:	APPROVED BY:	DRAWN BY: B. RUTHMAN
DATE: 8-27-01		REVISED: 6-1-13

(500 GAL. POLY WATER TANK) 20 GAL. "A" & 30 GAL. "B" FOAM

NOTE: PUMP PANEL CONFIGURATION IS PER LAST APPARATUS BUILD. NFPA COMPLIANCE CAN BE OBTAINED WITH PANEL RECONFIGURATION

DRAWING NUMBER 1-N