

LEFT SIDE VIEW

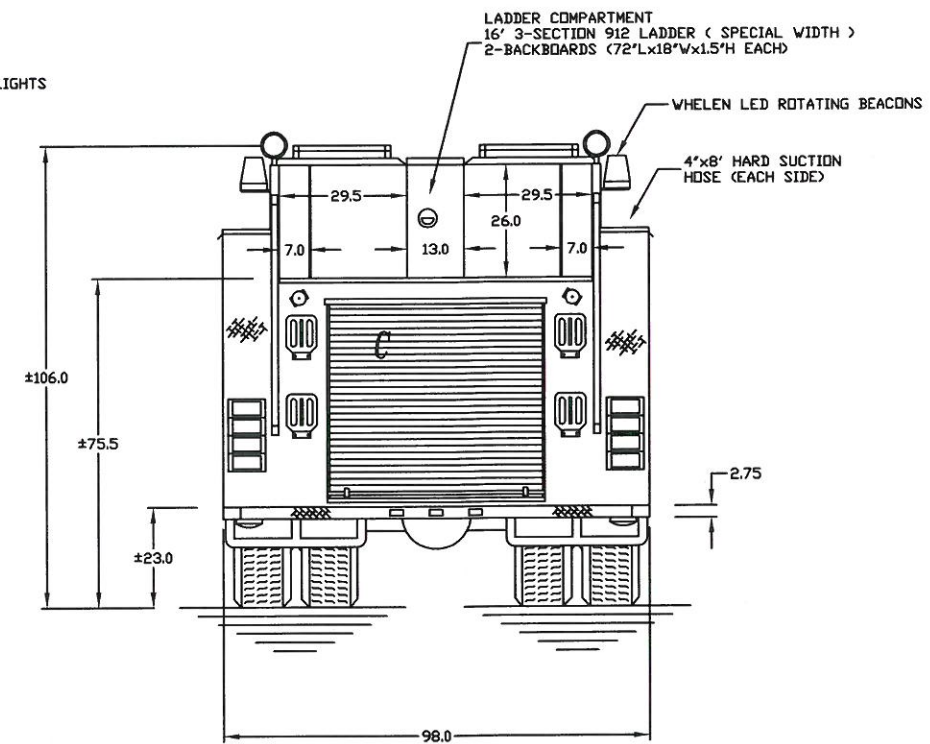

REAR VIEW

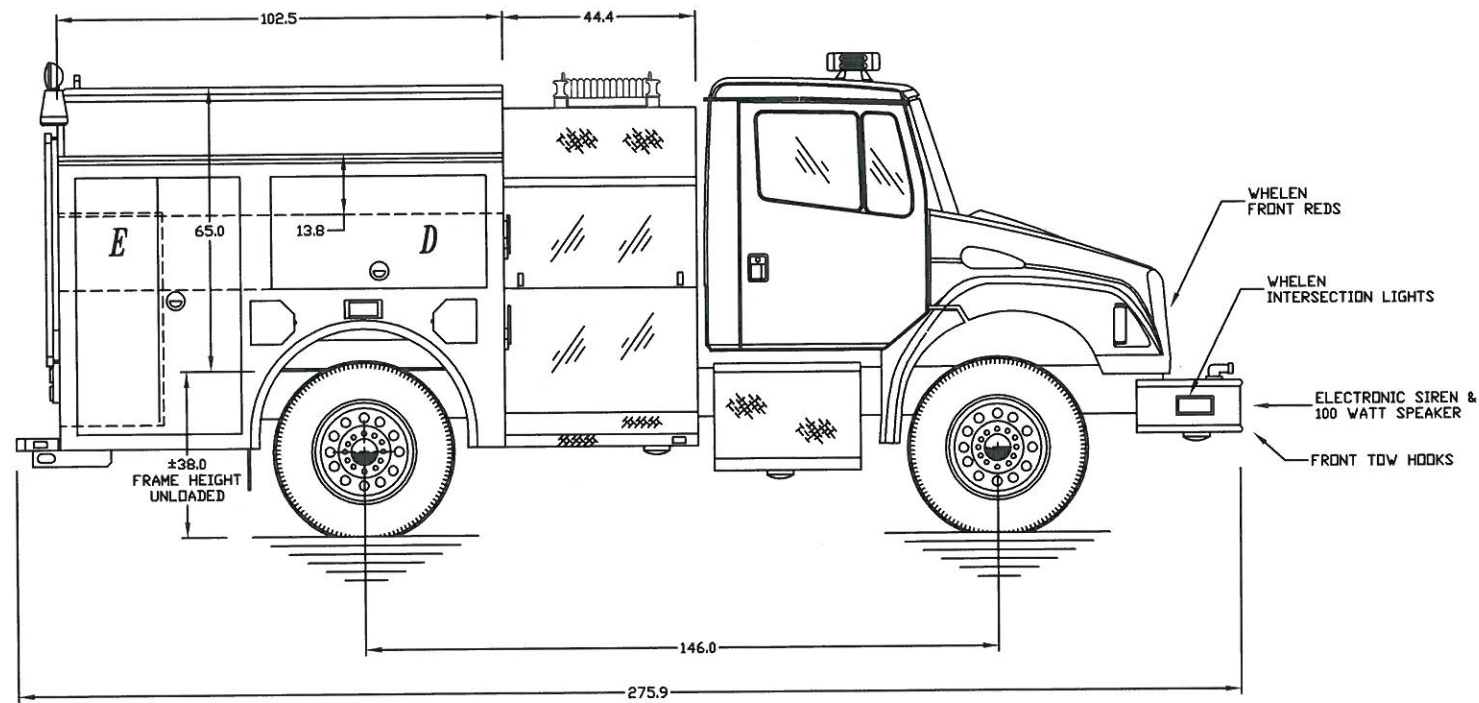

RIGHT SIDE VIEW

COMPARTMENT DIMENSIONS	
INSIDE	OPENING
A. 60.5"Wx30"Hx13"D	A. 49.5"Wx25"H
B. 42"Wx60"Hx13/24"D	B. 38"Wx55"H
C. 50/72"Wx45.75"Hx24"D	C. 50"Wx40.75"H
D. 60.5"Wx30"Hx13"D	D. 50"Wx25"H
E. 42"Wx60"Hx13/24"D	E. 38"Wx55"H
HI-TECH EMERGENCY VEHICLE SERVICE 444 W. GREGER ST. OAKDALE, CA. 95361 (209)847-3042	
YOLO F.D.	
SCALE:	APPROVED BY:
DATE: 8-2-11	REVISIONS: 2-10-12
500 GAL. POLY WATER TANK	
CAD PRODUCED DRAWING	
DRAWING NUMBER 1-B	

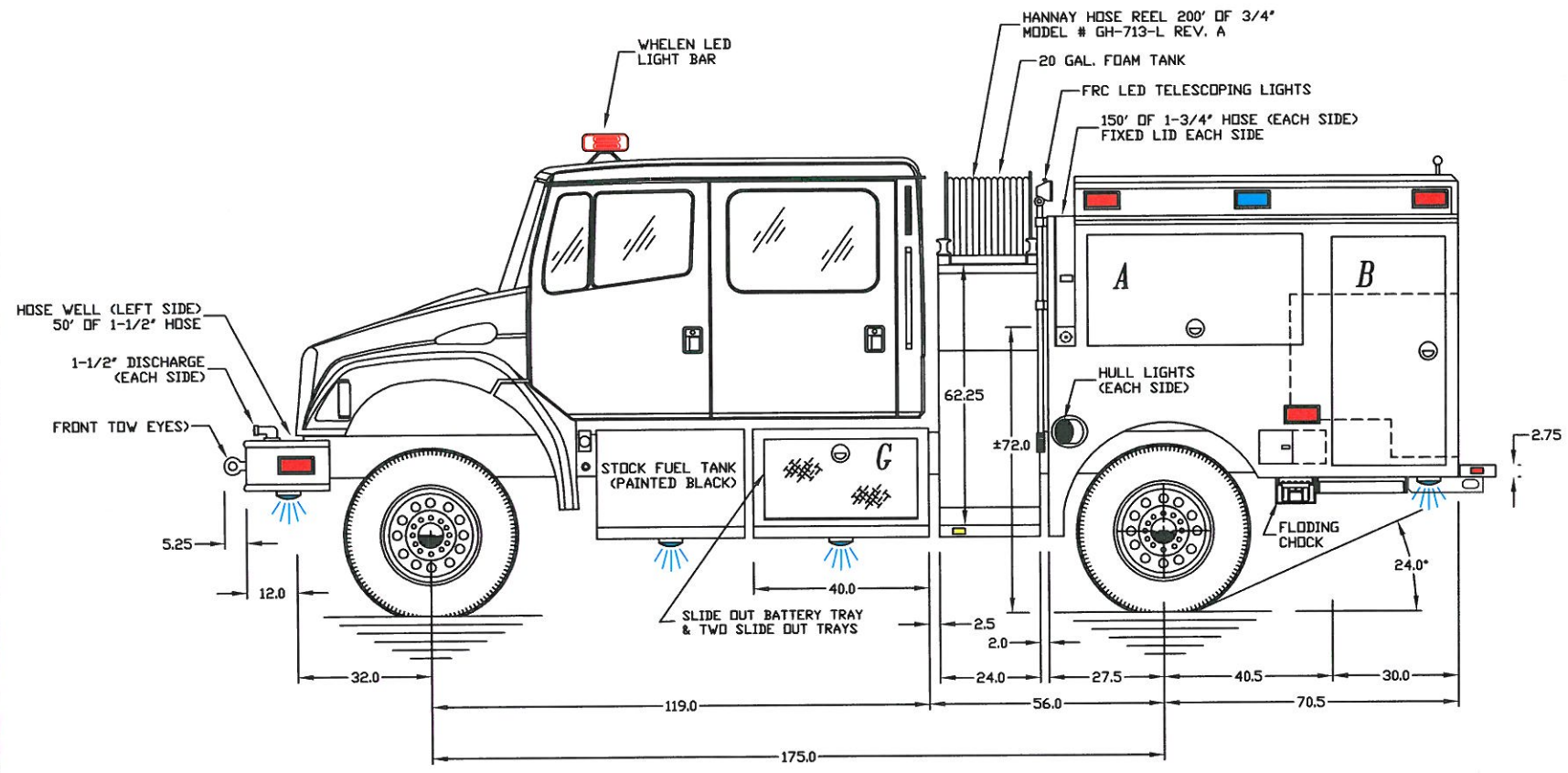

LEFT SIDE VIEW

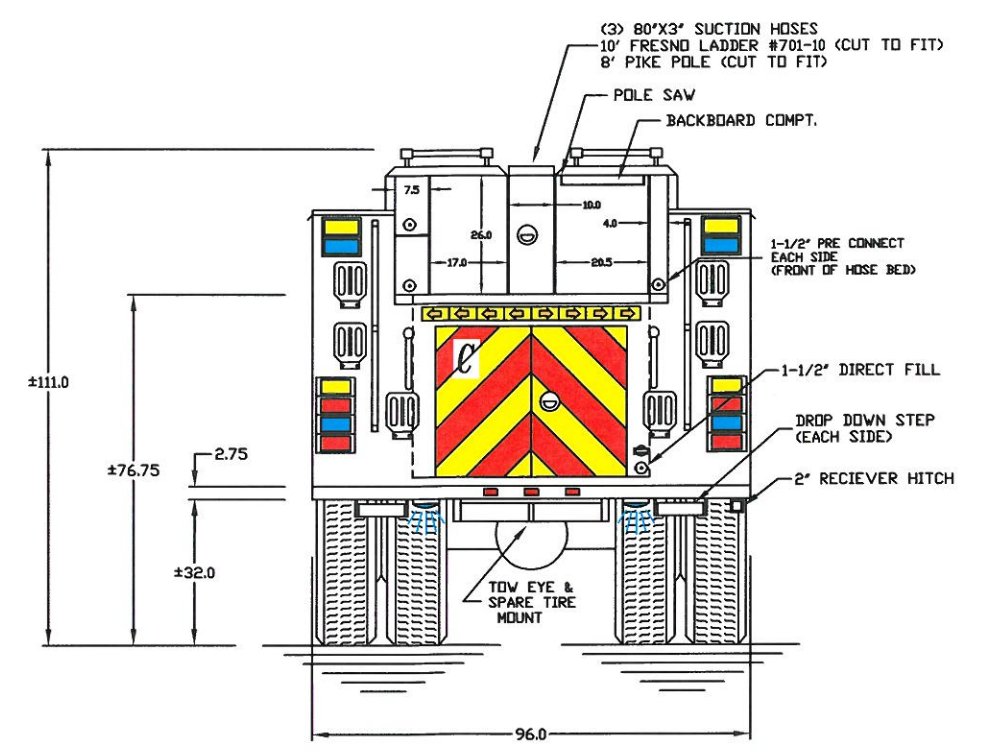

REAR VIEW

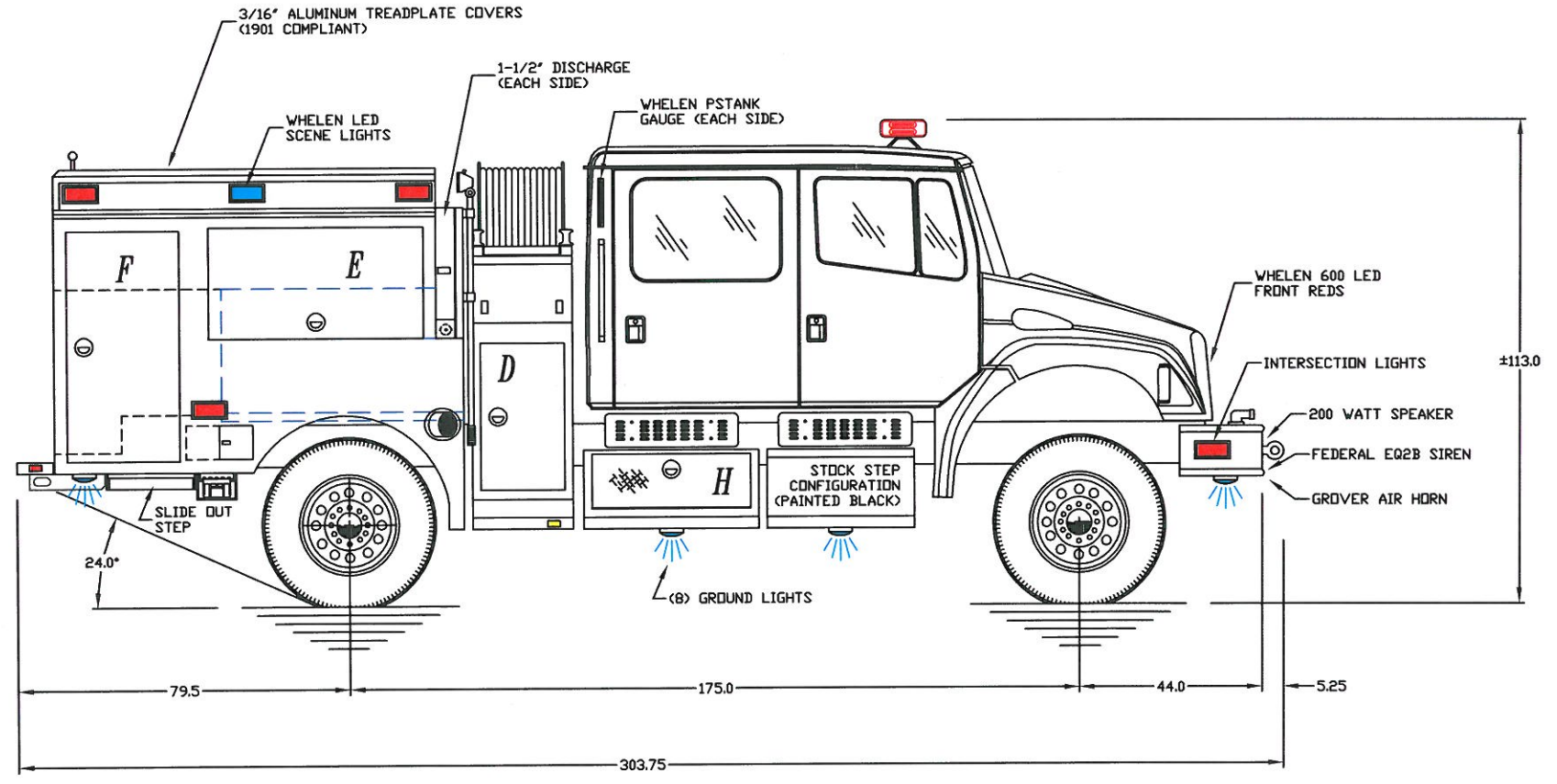

RIGHT SIDE VIEW

COMPARTMENT DIMENSIONS	
INSIDE	OPENING
A. 61.5"Wx32"Hx18"D	A. 51.5"Wx28"H
B. 30"Wx60"Hx18/22"D	B. 27"Wx56"H
C. 52"Wx38"Hx16/40"D	C. 38"Wx33"H
D. 19.5"Wx34"Hx15.75"D	D. 19.5"Wx34"H
E. 61.5"Wx32"Hx18"D	E. 51.5"Wx28"H
F. 30"Wx60"Hx18/22"D	F. 27"Wx56"H
G. 40"Wx19"Hx24"D	G. 37"Wx15.5"H
H. 40"Wx16"Hx21.5"D	H. 37"Wx11"H

HI-TECH EMERGENCY VEHICLE SERVICE
 444 W. GREGER ST. OAKDALE, CA. 95361 (209)847-3042

MARIN COUNTY F.D.

SCALE:	APPROVED BY:	DRAWN BY: B RUTHMAN
DATE: 2-1-12		REVISED: 3-28-13

500 GAL. WATER TANK / 20 GAL. FOAM TANK

NOTE: ALL DIMENSIONS ARE APPROXIMATE	DRAWING NUMBER 1-C
--------------------------------------	-----------------------