

RIGHT SIDE VIEW

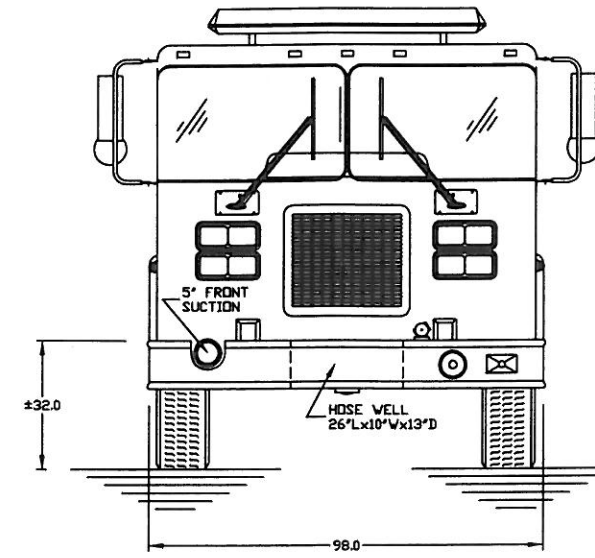

FRONT VIEW

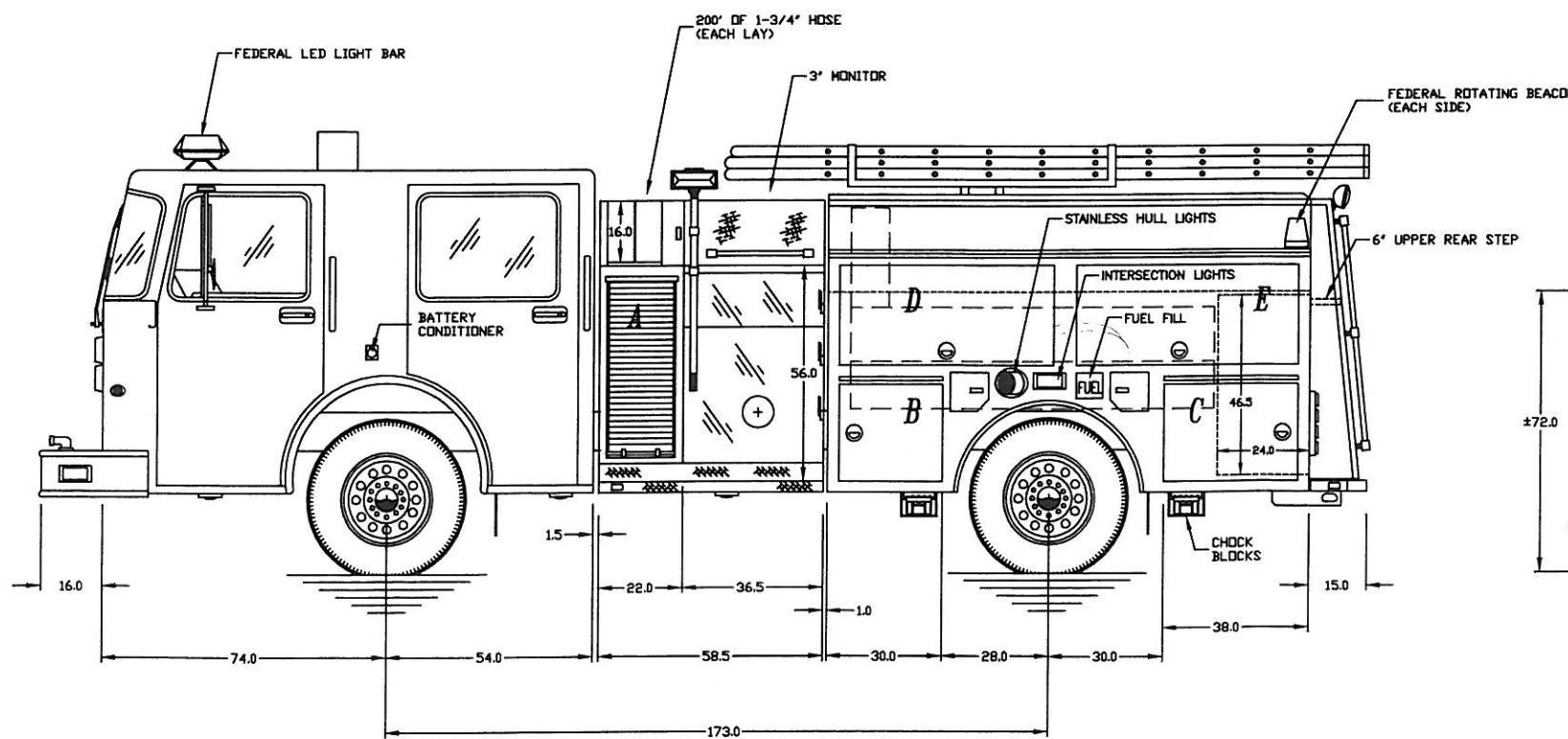

LEFT SIDE VIEW

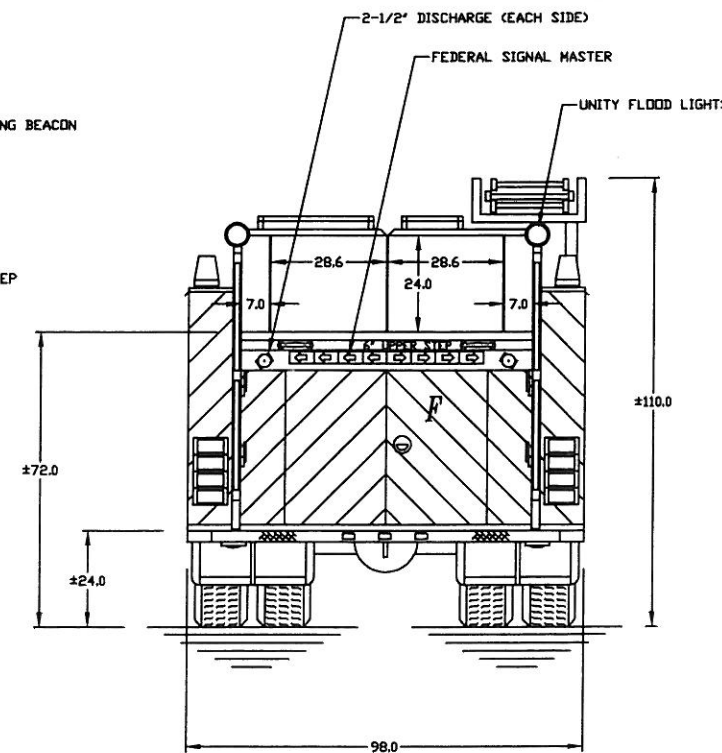

REAR VIEW

COMPARTMENT DIMENSIONS

INSIDE	OPENING
A. 22"Wx52"Hx78"D	A. 43"Hx18"W
B. 30"Hx30"Wx24"D	B. 25"Hx27"W
C. 30"Hx38"Wx24"D	C. 25"Hx35"W
D. 30"Hx63"Wx13"D	D. 25"Hx56"W
E. 30"Hx63"Wx13"D	E. 25"Hx56"W
F. 46.5"Hx50"Wx24"D	F. 40"Hx50"W
G. 60"Hx30"Wx13/24"D	G. 55"Hx27"W
H. 30"Hx39"Wx13"D	H. 25"Hx30"W
I. 60"Hx38"Wx13/24"D	I. 55"Hx35"W

HOSE BED DIMENSIONS
72"W x 24"H x 126"D

HI-TECH EMERGENCY VEHICLE SERVICE
444 W. GREGER ST. OAKDALE, CA. 95361 (209)847-3042

HI-TECH DEMO

SCALE:	APPROVED BY:	DRAWN BY: B. RUTHMAN
DATE: 3-28-10		REVISED:

500 GAL. POLY WATER TANK / 25 GAL. FOAM TANK

CAD PRODUCED DRAWING DRAWING NUMBER 1-A