

LEFT SIDE VIEW

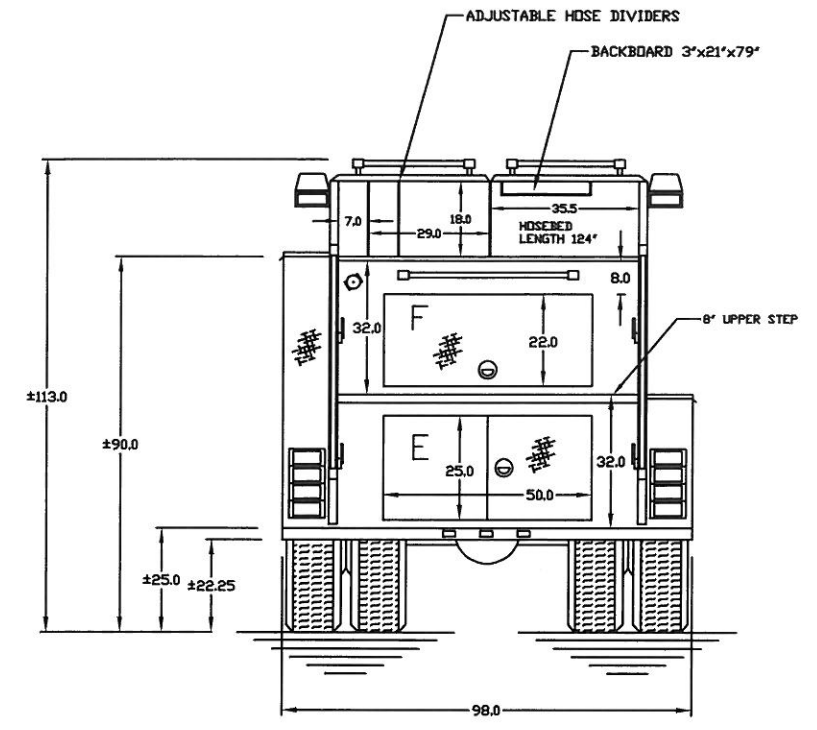

REAR VIEW

NOTE: ALL DIMENSIONS REFLECT UNLOADED HEIGHTS. -2" SHOULD BE TAKEN FROM HEIGHT MEASUREMENTS TO FIGURE LOADED HEIGHTS.

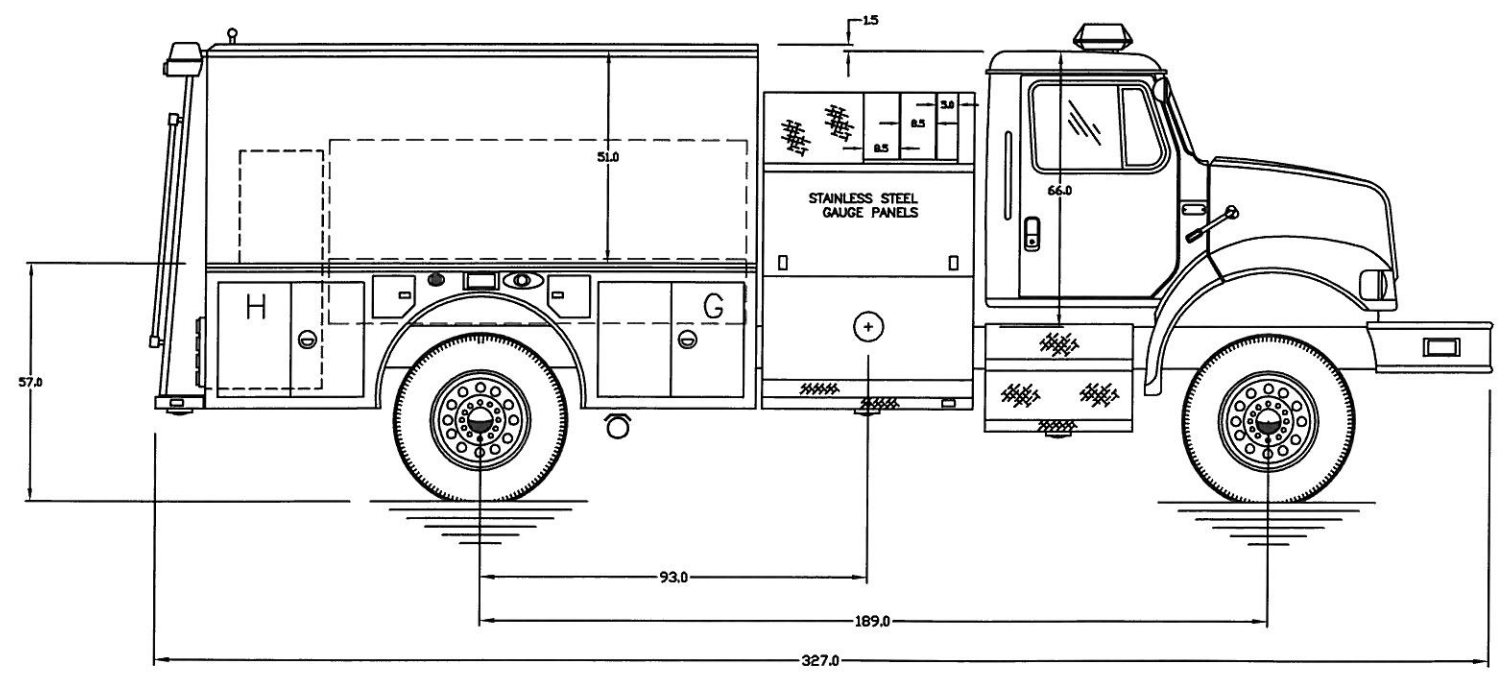

RIGHT SIDE VIEW

COMPARTMENT DIMENSIONS

| INSIDE | OPENING |
|------------------------|-------------------|
| A. 38" Wx 32" Hx 24" D | A. 35" Wx 27.5" H |
| B. 38" Wx 32" Hx 24" D | B. 59" Wx 27.5" H |
| C. 66" Wx 34" Hx 13" D | C. 59" Wx 29" H |
| D. 66" Wx 34" Hx 13" D | D. 53" Wx 29" H |
| E. 50" Wx 30" Hx 28" D | E. 50" Wx 25" H |
| F. 72" Wx 32" Hx 20" D | F. 50" Wx 22" H |
| G. 38" Wx 32" Hx 24" D | G. 35" Wx 27.5" H |
| H. 38" Wx 32" Hx 24" D | H. 59" Wx 27.5" H |

HI-TECH EMERGENCY VEHICLE SERVICE
444 W. GREGER ST. OAKDALE, CA. 95361 (209)847-3042

UKIAH VALLEY FIRE DISTRICT

| | | |
|----------------|--------------|---------------------|
| SCALE: | APPROVED BY: | DRAWN BY: B RUTHMAN |
| DATE: 11-17-09 | | REVISED : |

1000 GAL. POLY WATER TANK/20 GAL. FOAM TANK

CAD PRODUCED DRAWING

DRAWING NUMBER
1-A